

IMCOS-5657 Panel mounting Electric Slave Clock with 3 hands

Crouse-Hinds
by EATON



Product Description

IMCOS-5657 is a forward and backward electric slave clock with 3 hands, suitable for ship's applications.

It can be driven with 30 sec and 0.5 sec polarized pulses by IMCOS-3510 Master Clock.

Features

- Hands driving
 - Minute hand: 30 second leap;
 - Second hand: 0,5 second leap.
- Minute by minute forward or backward facility by IMCOS-3510 Master Clock.
- Fast forward or fast backward (standard one hour) facility by IMCOS-3510 Master Clock.
- Second adjust switch in optional external panel, IMCOS-5650-SEC.
- RoHS and CE certified.
- Stainless steel frame.

IMCOS™ System is type approved by seven marine class societies.



Gitiesse Srl
via Ponte Polcevera 8/14
16161 Genova, Italy
Sales Enq. IT: +39 010 7416801

Hazardous Area Communications (USA)
3413 North Sam Houston Parkway West,
Suite 212, Houston, TX 77086, USA
Sales Enq. USA: +1 (713) 937 9772

Gitiesse

Web: www.gitiesse.com
E-Mail: gitiesse@gitiesse.com

Specification

Certifications:	RoHS No 12 - JKR06*567-002.
Material:	Stainless Steel Frame.
Mounting:	Console or Panel Mounting.
Cable Glands:	Rear rubber ring for cable entry (diameter 25 mm).
Wiring:	Screw terminal inside. Cable type: 5 x 1,5 Screened.
Dimensions:	Depth 95 mm, External Diameter 175 mm.
Weight:	0,9 Kg.
Ingress Protection:	IP 44.

IMCOS-5657 Dimensions & Wiring

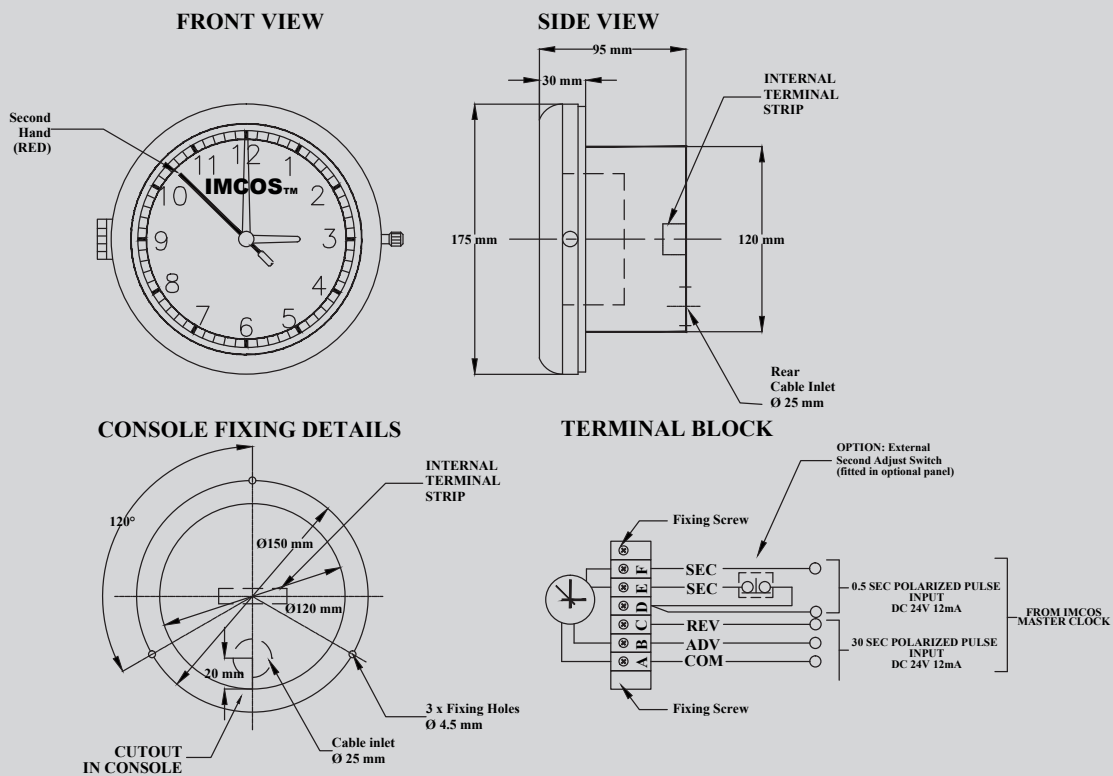

Ordering Requirements

The following code is designed to help in selection of the correct unit. Build up the reference number by inserting the code for each component into the appropriate box.

Model	Accessories
IMCOS-5657	IMCOS-5650-SEC Second adjust switch